

Instruction Manual

FM450



NOTE: Owner/Operator must read and understand this instruction manual before using the mover.

Contents

- 1. Application**
- 2. Specifications**
- 3. Assembly**
- 4. Precautions and Preparation**
- 5. Operation**
- 6. Care and Maintenance**
- 7. Parts Lists & Exploded Figures**

SERVICE:

Hercules Complete Lifting Solutions

Head Office: Unit 1, 87 Reserve Rd

ARTARMON NSW 2064

Toll Free: 1800 649 603

Phone: (02) 9966 5600

THANK YOU VERY MUCH FOR CHOOSING OUR HYDRAULIC EQUIPMENT MOVER. FOR YOUR SAFETY AND CORRECT OPERATION, PLEASE CAREFULLY READ THE MANUAL BEFORE USE.

NOTE: All the information reported herein is based on data available at the time of printing. The factory reserves the right to modify its own products at any time without notice or incurring in any sanction. Please verify with the factory for possible updates.

1. Application

The manual equipment mover has been developed for lifting and transporting of switch cabinets and other large regular objects. For this reason, its support supports are lined with foam rubber to prevent the goods being transported from damage.

Since the hydraulic equipment mover consists of two units, rectangular objects of varying length can be moved using a minimum of space. Due to the weight of the steel cabinet on the platform, it will hold itself in position when the units are standing vertically, and the frame of the platform is in contact with its sides.

The securing strap, which must be fastened correctly on both sides, is an additional absolute necessity.

The steering handles have a full lock of 180°, this means that goods to be transported may be moved in every direction. The platforms are raised by operating the lever of the pump; this lever must not be used for pulling or pushing the BIMOBIL. The goods transports are lowered by twisting the manual release valve of the compact hydraulic system to the left.

Great care must be taken when lowering the platform, since the speed depends on the aperture of the valve as well as the weight of the goods to be transported. Before pumping up the system to raise the platforms the valve must be twisted to the right until the stop to close it.

Using an old crate, try a few "dry runs" with the transport units moving equipment with them. If you operate properly, our hydraulic equipment mover will help you to move switch cabinets, equipment etc quickly and safely.

2. Specifications

Model	Capacity	Lifting Height	Net Weight
FM450-1	4500kg	150mm	220kg
FM450-2		150mm	218kg

3. Assembly

Remove the fork pin at the free end of the track rod, set the steering handles parallel to each other, and push the fork of the track rod over the arm of the steering handle. Then replace the previously-removed fork pin through the fork and arm and secure it with clip.

The second unit is assembled in the same way.

4. Precautions and Preparation

4.1 The floor must be absolutely level, smooth and clean. There must be no inclines or slopes to be moved over. Make sure that the floor and the floor covering are strong enough to stand up to the loading imposed by the wheel and whether they can take the weight of the equipment being transported.

4.2 Check whether the piece of equipment to be transported contains any loose objects. These will have to be removed or secured against slopping out of position.

4.3 Check whether the piece of equipment is strong enough for the two opposite sides to take the weight of the piece via the transport units' platforms, and whether the upper supports of the transport units can hold the equipment to be transport without damaging it.

4.4 Find the weight of the piece of equipment to be transported. The maximum load of 4500 kg/pair = 2250 kg for each unit must not be exceeded.

4.5 Find the center of gravity of the equipment to be transported. Along the equipment base, it is the decisive for the load that a single transport unit can bear, across the base, for the center of the transport unit, and, in connection with the height, for the moment of tilting that occurs when moving the equipment. When in use, the height of the center of gravity must not exceed 0.8m. The distance of the transport units to one another must not be less than 0.5m and not gravity 4.0m (equipment of the securing straps).

4.6 Never use this equipment for towing behind a vehicle.

5. Operation

Before use, the transport components should be checked for function, and for any damage. If there are visible defects, the components should not be used. Damaged parts must be replaced. Since the hydraulic equipment mover consists of two parts, it is necessary for two persons to operate them.

Before transport cabinets, the platforms should be let down to the floor until the transport units are standing vertically.

Push the platform of the units under the side faces (narrow faces) of the cabinet until the top and bottom of the transport platform frame are resting against it. The centers of the platform must be beneath the center of gravity of the cabinet.

Place the securing straps in position and tighten them. The straps will connect both units and, when used correctly, prevent them from slipping out of their position holding the goods to be transported. Here, the strap ends must be under direct tension, that is, the straps must not be pulling round the edge of a cabinet, etc. If the position of the center of gravity makes it necessary for the cabinet being transported to project on one side out of frame, or, due to its width, it projects on both sides, an additional strap surrounding it must be employed. This must be fed through the strap loops on the units. However, the maximum overhang must not be more than 200 mm.

Pump up the platform about 1 cm, and carefully check how firmly the cabinet to be transported is standing on the platforms. It may be that the transport units will have to be moved to another position.

Both platforms must be raised at the same time and to the same

amount. For the transport itself, the height off the floor must be a maximum of 2 cm only. When moving the cabinets, only push the transport units and choose the way to the cabinet's new position so that, if possible, it is only moved lengthwise. When moving cabinets sideways, always take the greatest care; there is a great risk of the cabinets tilting over. Avoid any pushing movements.

The cabinet being transport must not be left unattended standing on the equipment; it must always be lowered onto the floor.

The securing straps may only be opened when the cabinet being transported, or the platforms, is standing on the floor.

Never use this equipment for towing behind a vehicle.

6. Care and Maintenance

Our hydraulic equipment mover only requires little care and maintenance, but this must be carried out regularly. Depending on its use, the spindles and gear wheels must be re-greased weekly or monthly, using standard multi-purpose grease. For this, the spindle may be reached using a brush through the slot in the guide rail. The gear wheels are also greased using brush, by first levering off the gear-housing lid with a screwdriver. The lid should be pressed down firmly to close it again. The units' function should be tested.

7. Parts Lists & Exploded Figures

7.1 For Lifting Height of 100mm

Item No.	Description	Qty
1	Dust-proof Cover	4
2	Cushion	2
3	Woven Stripe	1
4	Lifting Frame	1
5	Split Ring 8	1
6	Handle Assy.	1
7	Hand Grip	1
8	Synchronous Rod	2
9	Hydraulic Jack	1
10	Fixing Pin(I)	2
11	Spilt Ring 6	2
12	Fixing Pin (II)	1
13	Cylindrical Spring Pin	2
14	Nylon Washer	2
15	Supporting Frame	1
16	Bolt M6×20	2
17	Supporting Rod	2
18	Bolt M10×70	2
19	Cargo Lashings	1
20	Nut M10	2
21	Thrust Bearing 51204	2
22	Dust-proof Ring	2
23	Bolt M12×90	2
24	Wheel	2
25	Liner Bushing	4
26	Axle Sleeve	2
27	Nut M12	2

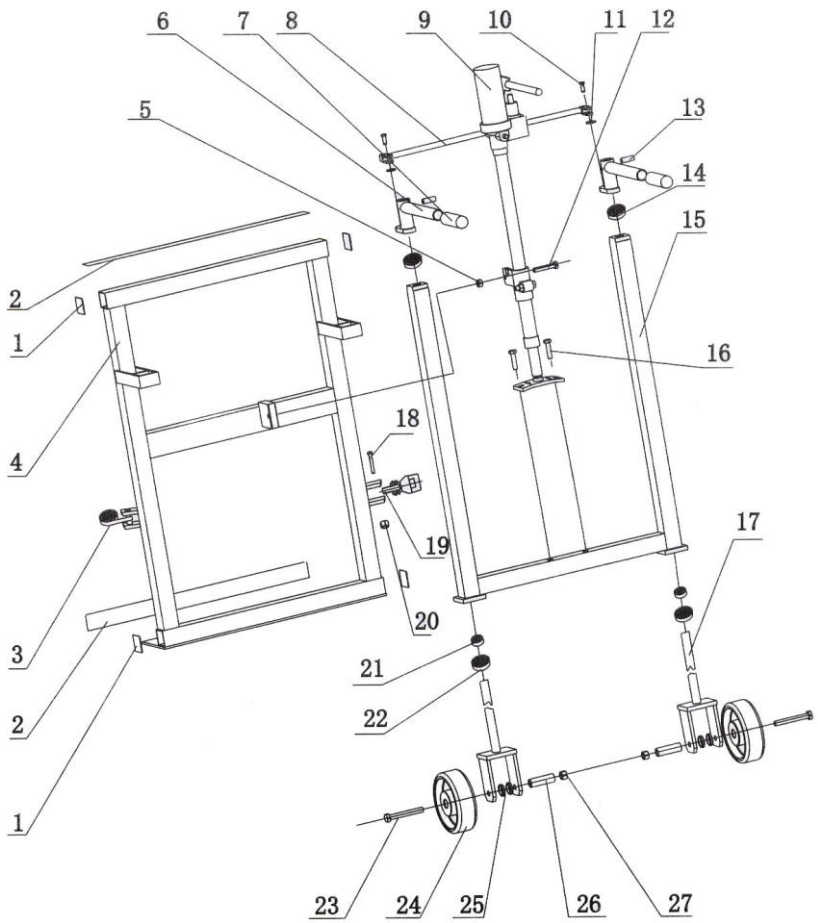

7.2 For Lifting Height of 250mm

Item No.	Description	Qty
1	Dust-proof Cover	4
2	Cushion	2
3	Woven Stripe	1
4	Lifting Frame	1
5	Split Ring 8	1
6	Handle Assy.	2
7	Hand Tube	1
8	Washer	2
9	Hydraulic Jack	1
10	Pin	2
12	Fixing Pin (II)	1
13	Cylindrical Spring Pin	2
14	Nylon Washer	2
15	Supporting Frame	1
16	Bolt M6×20	2
17	Supporting Rod	2
18	Bolt M10×70	2
19	Cargo Lashings	1
20	Nut M10	2
21	Thrust Bearing 51204	2
22	Dust-proof Ring	2
23	Bolt M12×90	2
24	Wheel	2
25	Liner Bushing	4
26	Axle Sleeve	2
27	Nut M12	2

